

AM 580

Version:1.0_221013_EN



Artificial Mouth 580 is designed for accurate and repeatable electroacoustic measurements. It has extraordinary distortion performance, typical value is: after equalization to 94dB SPL, 25mm distance, the THD can be lower than 1%.

PM 0083 + AM 580, is a classical solution for quality control testing of frequency response and distortion of mobile phone, telephone transmitters and close-talking microphones.

Features

- Low distortion
- Low sensitivity to temperature and humidity changes

Specification

THD	200Hz – 10kHz : criteria 1% (94dB SPL, 25mmMRP)
Frequency Response	After equalization 94dB ± 0.1dB (100Hz - 10kHz)
Compensation value (EQ Range)	Anechoic box, smaller 20dB Anechoic room, smaller 15dB
Impedance	4 ohm
Continuous output power	10W
Sound ring diameter	Ø20mm
Lip ring	Out : Ø51mm
	Height : 25mm
Diameter	Ø102mm
Height	105mm
Weight	1160g
Interface	BNC

Curve

After EQ, 94dB SPL (20mm MRP)

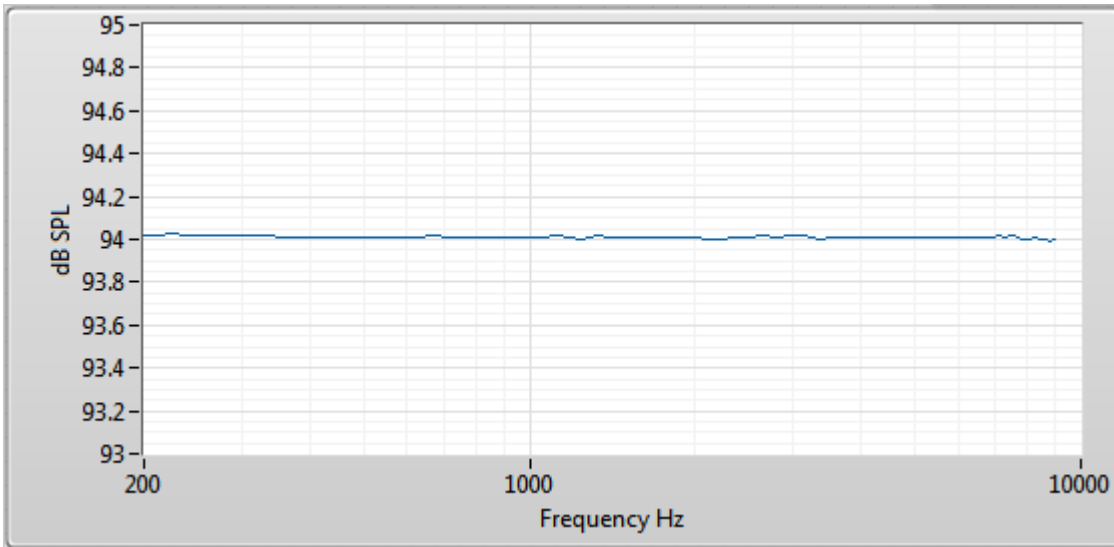

After EQ, 94dB SPL THD (20mm MRP)

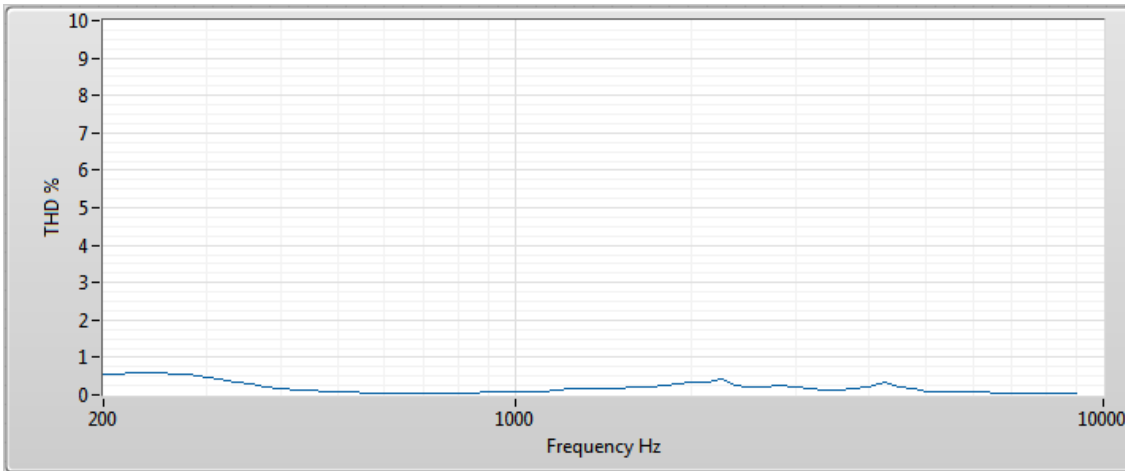

Dimension

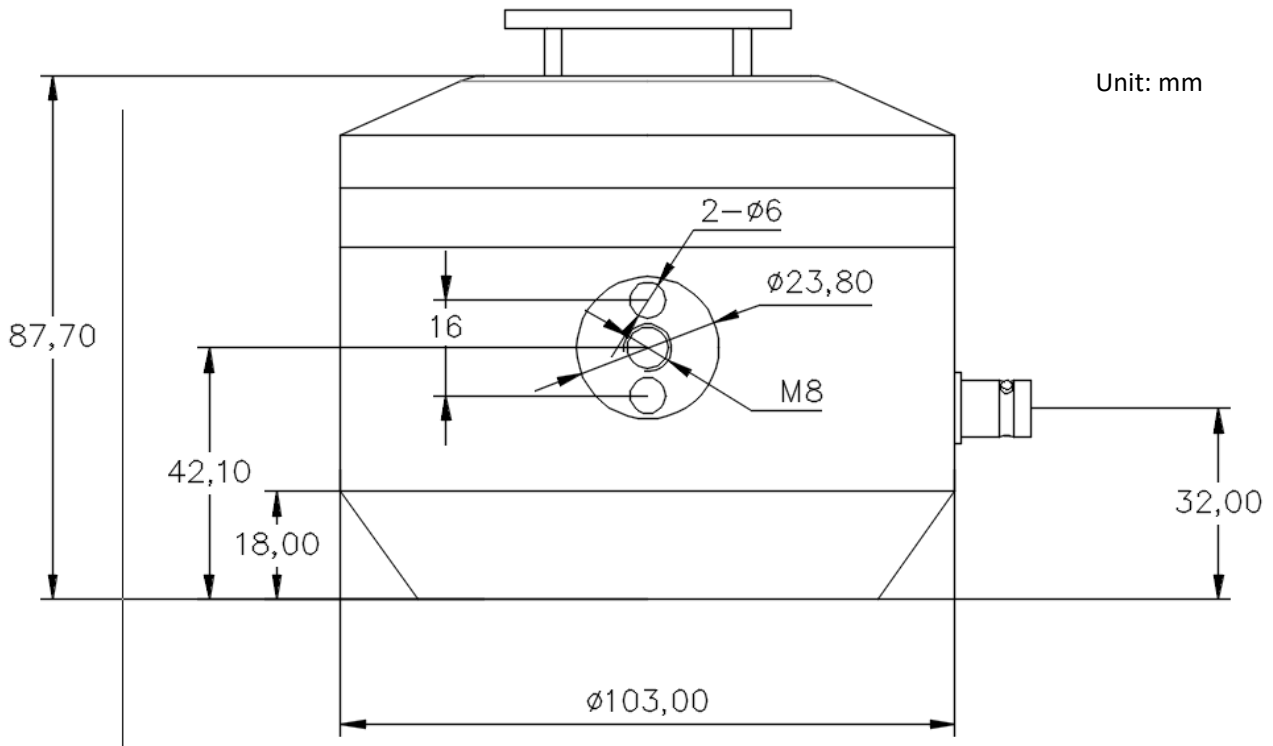

MegaSig reserves the right to change specifications and accessories without notice.



www.megasig.com

MegaSig Measurement & Control Technology Co.,Ltd 电

Tel: +86.0755-8950.8393

Fax: +860755-8950.8392

Sale mail: sale@megasig.com

Support mail: support@megasig.com

Add: Room 1002, Unit 2, Building 1, Hongxing Chuangzhi Plaza,
Guangming District, Shenzhen,China